

Residential BASIC BRACING METHOD REQUIREMENTS Checklist & Guide for a Building Permit (Per the 2015 IRC as amended by St. Louis County Ordinances for 1- & 2-Family Dwellings)



This **Residential Basic Bracing Method** Checklist of requirements is based on St. Louis County's (SLCO) policies and construction codes as amended and adopted by ordinance. See the Codes list below. This checklist is not a substitute for those codes and ordinances but serves as a guide to reading them. More information and explanation are provided in the St. Louis County Single-Family Dwelling Design Checklist, and in commentaries and interpretations published by St. Louis County and acknowledged code organizations.



List of Applicable Codes and Ordinances:

2015 International Residential Code (IRC) & Ordinance #27,654-Ch.1116 ("R" "G", "N", and "M" references and Appendix K - Sound Transmission).

2015 International Building Code (IBC) & Ordinance #27,654-Ch.1116\5 ("B" references).

For inquiries regarding the information provided in this guide, please contact:

St. Louis County Permit Processing _____ (314) 615-5184

St. Louis County Building Plan Review _____ (314) 615-5485

St. Louis County's Municipal Contracts Matrix shows those municipalities that currently contract for its Code Enforcement services. The Matrix is on our web site at <https://stlouiscountymo.gov/st-louis-county-departments/transportation-and-public-works/residential-building/>

For the electronic plan review, scan QR code or visit us online at <https://stlouiscountymo.gov/st-louis-county-departments/transportation-and-public-works/electronic-plan-review/>



Sections from the Codes, their Referenced Standards, and St. Louis County Ordinances, are shown at ends of statements and are *italicized* in parentheses (.).

Submittal Requirements: Drawings, Details & Notes



The following are the requirements of the St. Louis County Basic Bracing Method for use on 1- and 2-family dwellings. Specific Code and Ordinance Sections may be provided in parentheses (.)

- One and Two-family dwellings located in either Wind Exposure A or B may use the Basis Bracing Method provided in this checklist as an alternate to the prescriptive bracing provisions provided in the 2015 International Residential Code (2015-IRC) Section R602.10 (*SLCO Rev. Ord. R602.13*).
- **Notice:** Bracing proposed outside the scope of this checklist shall be provided in drawings and calculations properly sealed by a Missouri registered engineer or architect (*R301.1.1*).
- The construction drawings submitted for a permit using the Basic Bracing Method must provide in plans or elevations the locations and widths of all braced wall panels, and provide their construction details, in accordance with this checklist (*SLCO Rev. Ord. R602.13*).
 1. The building exterior walls shall be sheathed with 7/16" or thicker plywood or OSB wood structural panels. The wood structural panels shall be applied to all exterior walls, gable ends, and band boards. All vertical joints between panels shall be blocked. Horizontal joints in braced wall panels shall be blocked (*SLCO Rev. Ord. R602.13.1*).
 2. Exterior braced wall lines shall be determined in accordance with 2015-IRC Section R602.10.1, exclusive of 2015-IRC Section R602.10.1.3. Braced wall panels shall be located in every exterior braced wall line in accordance with the following criteria (*SLCO Rev. Ord. R602.13.2*):
 - a. The outside edge of the first braced wall panel meeting the width established in Table R602.13.3 shall be a maximum of 12'-6" or less from each end of the braced wall line. The outside stud of the first braced wall panels closest to the end of the braced wall line shall be secured with a hold-down device securing the end stud to the foundation with a minimum uplift design value of 800-lbs.
Exception: The 800 pound hold-down device is not required when the braced wall panel is placed at the end of the braced wall line and there is a 24"-wide full height sheathed wall placed 90 degrees to the end of the braced wall line and panel.
 - b. The centerline spacing of braced wall panels in a braced wall line may not exceed 25'-0".
 3. Braced wall panels shall be supported by continuous foundations or in accordance with 2015-IRC Section R602.10.9.

Show braced wall panel locations on the floor plans or on the exterior elevations. Each braced wall panel must meet the widths established in Table R602.13.3 below, without any openings or vertical or horizontal offsets to any panel:

**TABLE 602.13.3
BASIC BRACING PANEL WIDTHS**

		WIDTH OF SOLID PANEL ^{a, b}			
		8' wall height	9' wall height	10' wall height	12' wall height
Plywood/OSB Panel	3:1	32"	36"	40"	48"
Simplified Portal Wall ^c	6:1	16" ^d	18" ^d	20" ^d	24" ^d

a. Linear interpolation is permitted

- b. Wall height is the vertical distance from the bottom of the sole/sill plate to the top of the double top plate. An additional 2 inch variation in height is allowed for pre-cut stud framing.
 - c. The BASIC Portal Wall, where applicable, shall be constructed in accordance with the detail provided in Figure R602.13.3. The detail shall then be provided in the construction drawings submitted for a permit.
 - d. The BASIC Portal Wall width assumes the beam is placed directly under the top plate of the wall. A smaller width may be calculated for a lower top of beam height using the 6:1 height to width ratio.
4. Provide in the construction drawings submitted for a permit the applicable exterior wall corner plan detail(s) shown in Figure R602.13.4 (*SLCO Rev. Ord. R602.13.4*).
Exception: Braced wall panels that are located in accordance Section R602.13.2, which found above as Item 2.
5. When the perpendicular distance between the exterior braced wall lines exceeds 50'-0", a Missouri registered engineer or architect is required to provide properly sealed drawings that include the following certification on the bracing drawings (*SLCO Rev. Ord. R602.13.5*):

The interior and exterior wall configuration braces the structure in accordance with or equivalent to the lateral bracing provisions of Section R602.10 of the International Residential Code, 2015 edition or Section 2305 of the International Building Code, 2015 edition.
6. Wall height may not exceed 12'-0" (12'-2" actual maximum height). Walls greater than 12'-0" in height must be calculated, then designed and detailed in submittal drawings properly sealed by a Missouri registered Engineer or Architect. The sealed calculations and drawings must justify the bracing proposed is adequate to resist expected wind loads in both the longitudinal (racking and parallel) and transverse (perpendicular) directions (*SLCO Rev. Ord. R602.13.6*).
Exception: Structural calculations and details are not required in the following situations:
 - a. Longitudinal structural calculations are not required when there are no braced wall panels in that portion of a wall where the height exceeds 12'-0" and that greater wall height segment is within a prescriptive braced wall line on each of the adjacent stories.
 - b. Transverse structural calculations are not required if the wall exceeding 12'-2" complies with **Table R602.3.1** of the **2015 International Residential Code (IRC)**.
7. Braced wall panel connections to floor and roof/ceiling assemblies shall comply with **Sections R602.10.8 and R602.10.8.2** of the **2015 International Residential Code (IRC)**

QUESTIONS Regarding This Checklist's Content:

1. The highlighted text directly above was in the 2009-IRC Simplified Bracing Method Checklist. Are we keeping it for this checklist? The text is not in the 2015 IRC Ordinance.
2. The Sections referenced in item 7 are from the 2009-IRC, but are also in the 2015 IRC. Are we keeping item 7 for this checklist?

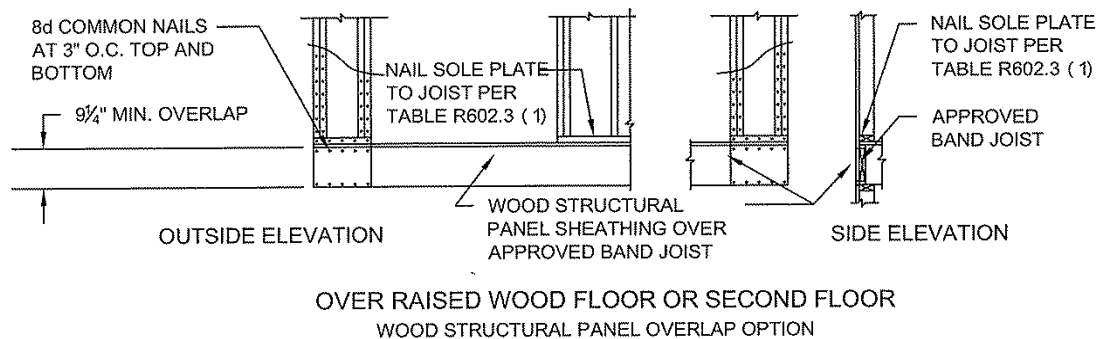
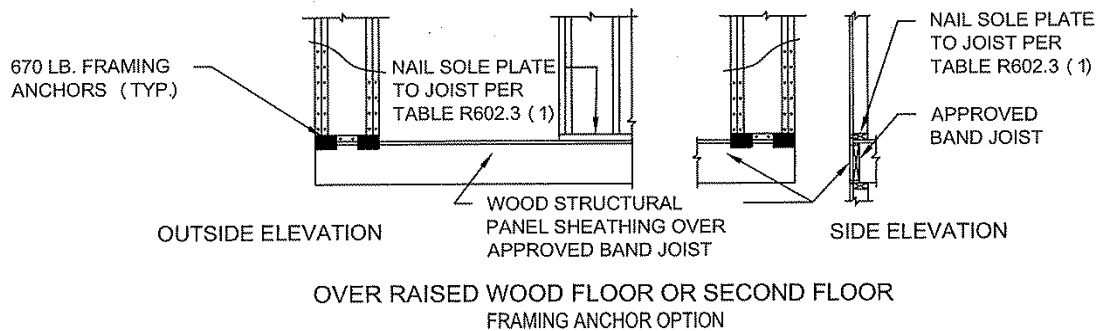
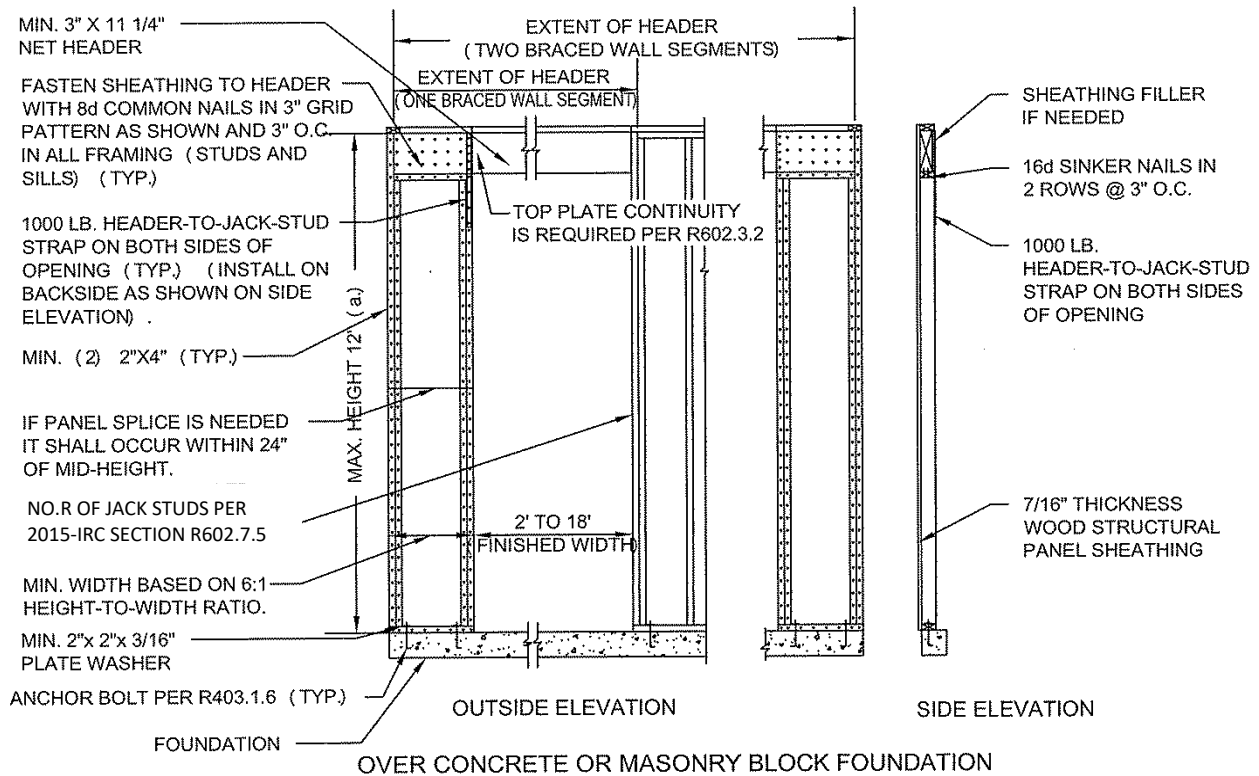
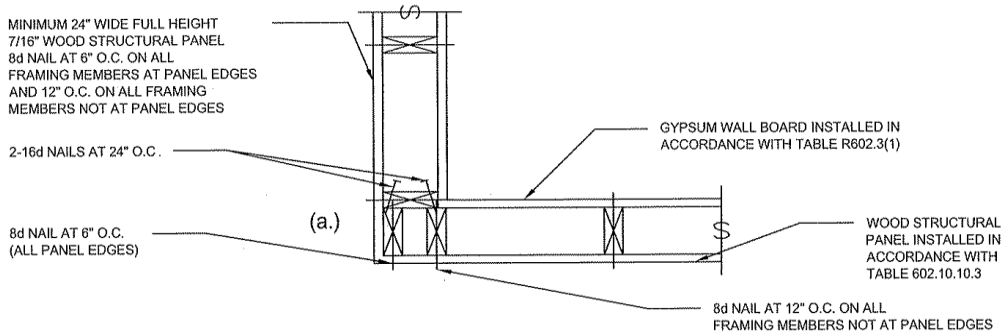
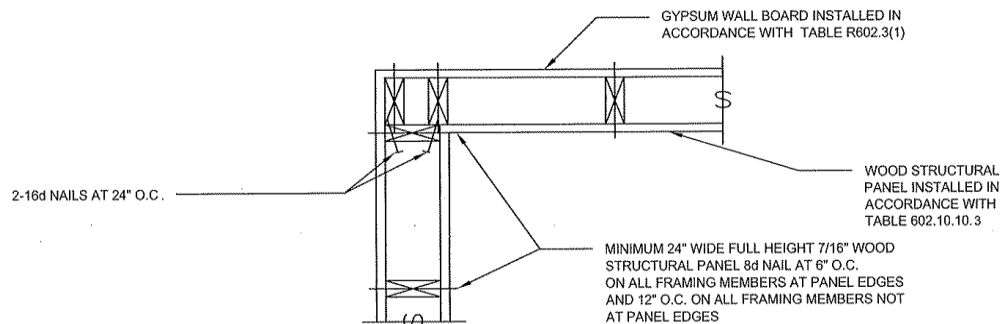

FIGURE R602.13.4
BASIC BRACING EXTERIOR CORNER FRAMING

- a. CRIPPLE WALL FRAMING CONSISTING OF STUD FRAMING, SINGLE BOTTOM PLATE, AND DOUBLE TOP PLATE MAY BE ADDED TO THE TOP OF THE NARROW PORTAL WALL AS LONG AS THE COMBINED HEIGHT OF THE TWO WALLS IS LESS THAN OR EQUAL TO 12 FEET AND THE TWO WALLS ARE STRAPPED TOGETHER ON THE INTERIOR SIDE WITH A 16 GAUGE METAL 1 1/2 INCH WIDE BY 21 INCH LONG STRAP. A MINIMUM 10 INCHES OF THE STRAP SHALL BE CONNECTED TO EACH WALL OR GABLE TRUSS WITH 9 - 16D NAILS FOR A TOTAL OF 18-16D NAILS IN THE ENTIRE STRAP. STRAPS SHALL BE LOCATED AT EACH END OF THE CONNECTED WALLS OR WALL AND GABLE TRUSS WHERE SPACE ALLOWS FOR THE 10 INCH LENGTH OF STRAP. THE SPACING BETWEEN THE STRAPS MAY NOT EXCEED 4 FEET ON CENTER. THE STRAPS SHALL NOT BE BENT HORIZONTALLY TO ACCOMMODATE WOOD FRAMING. IF APPLICABLE, NAILERS SHALL BE ADDED TO ONE OF THE WALLS OR GABLE END USING A MINIMUM OF 9-16D NAILS TO CREATE THE VERTICAL PLANE NEEDED TO MOUNT THE STRAP.



OUTSIDE CORNER DETAIL



INSIDE CORNER DETAIL

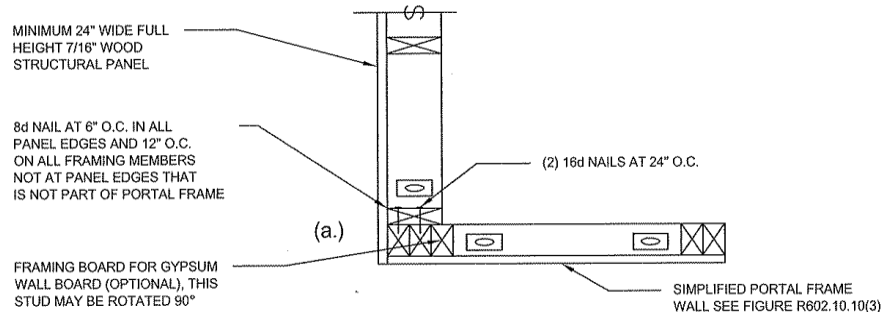

CORNER DETAIL
USED IN CONJUNCTION WITH SIMPLIFIED PORTAL WALL

WOOD STRUCTURAL PANEL INSTALLED IN ACCORDANCE WITH TABLE R602.3.3

**FIGURE R602.10.10.4
SIMPLIFIED BRACING EXTERIOR CORNER FRAMING**

- a. END STUD INDICATED ON THE ABOVE DETAILS MAY BE SHIFTED 7/16" TO ALLOW STUD FACE TO BE ALIGNED WITH SHEATHING, OR AN OPTIONAL NON-STRUCTURAL FILLER PANEL MAY BE USED.